



US 20190207159A1

(19) **United States**

(12) **Patent Application Publication**  
**Park**

(10) **Pub. No.: US 2019/0207159 A1**

(43) **Pub. Date: Jul. 4, 2019**

(54) **DISPLAY DEVICE AND ORGANIC LUMINESCENT DISPLAY DEVICE**

(30) **Foreign Application Priority Data**

Nov. 29, 2012 (KR) ..... 10-2012-0137336

(71) Applicant: **SAMSUNG DISPLAY CO., LTD.**,  
Yongin-si (KR)

**Publication Classification**

(72) Inventor: **Myoung-Seo Park**, Yongin-si (KR)

(51) **Int. Cl.**  
*H01L 51/52* (2006.01)  
*H01L 27/32* (2006.01)

(21) Appl. No.: **16/298,961**

(52) **U.S. Cl.**  
CPC ..... *H01L 51/5253* (2013.01); *H01L 27/3276*  
(2013.01); *H01L 27/3244* (2013.01)

(22) Filed: **Mar. 11, 2019**

(57) **ABSTRACT**

**Related U.S. Application Data**

(63) Continuation of application No. 15/871,115, filed on Jan. 15, 2018, which is a continuation of application No. 13/840,879, filed on Mar. 15, 2013, now Pat. No. 9,893,312.

Provided is a display device including: a structure including a display area and a peripheral area surrounding the display area; and an inorganic encapsulation thin film disposed on the display and peripheral areas. The peripheral area includes at least one inorganic surface portion having a closed shape continuously.

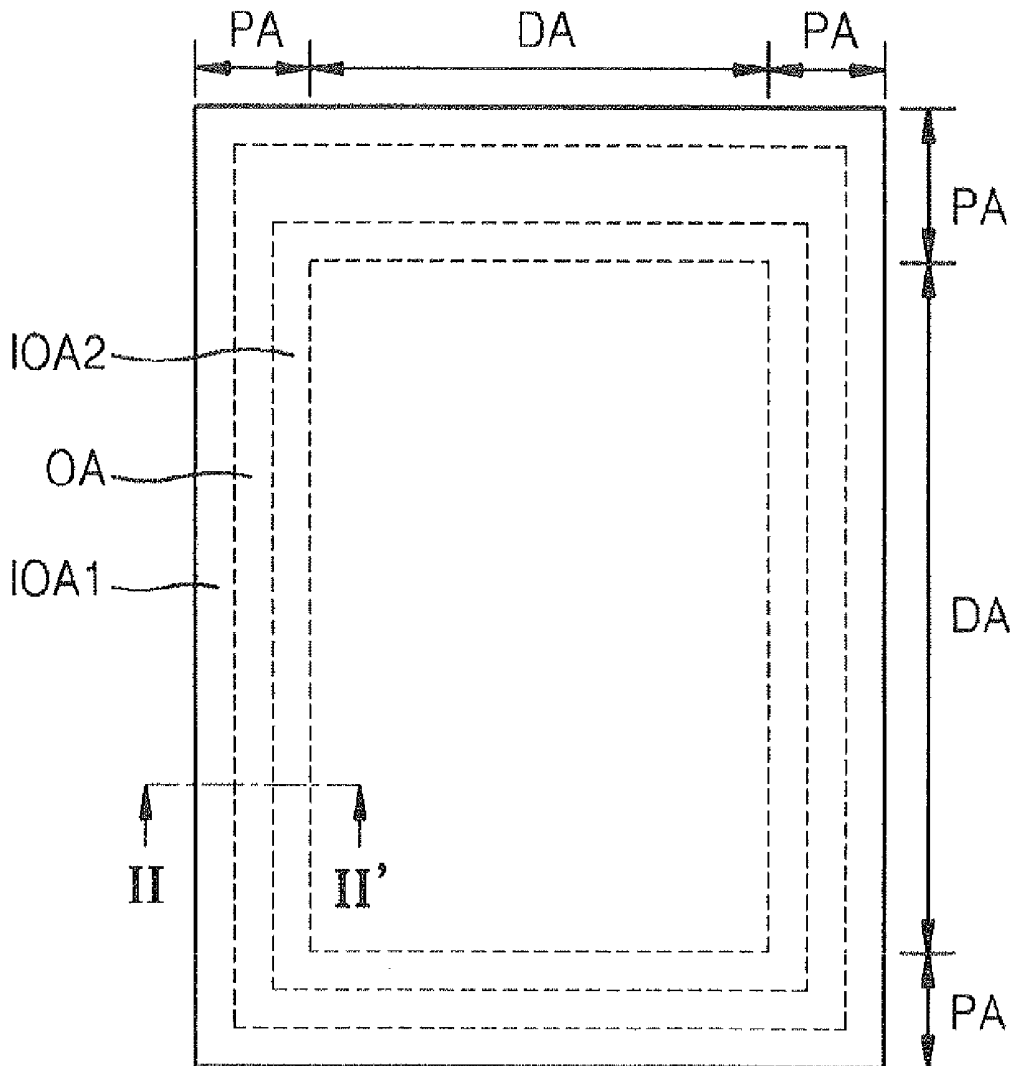

FIG. 1

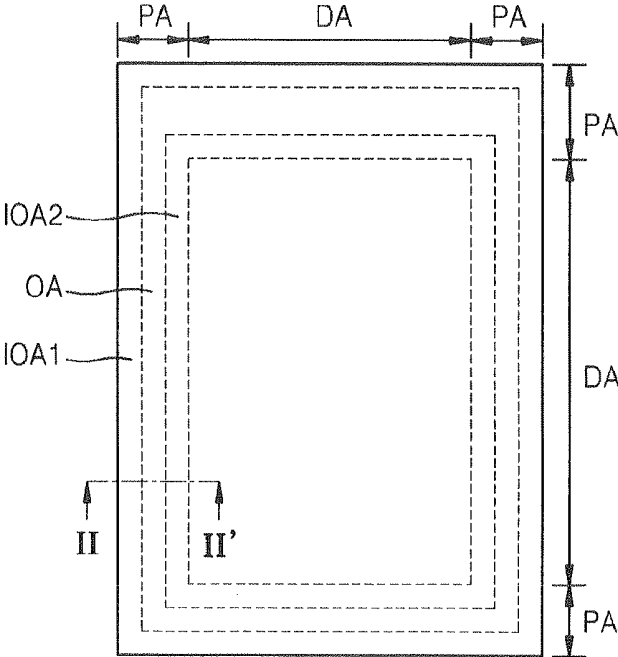



FIG. 3

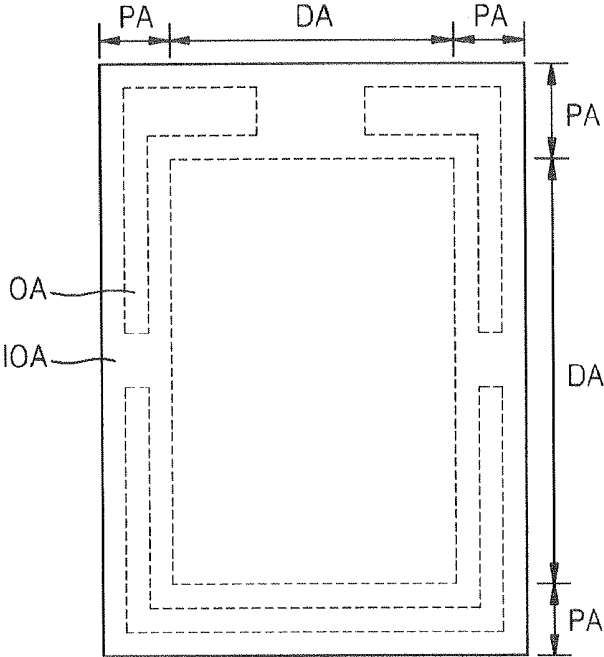

FIG. 4

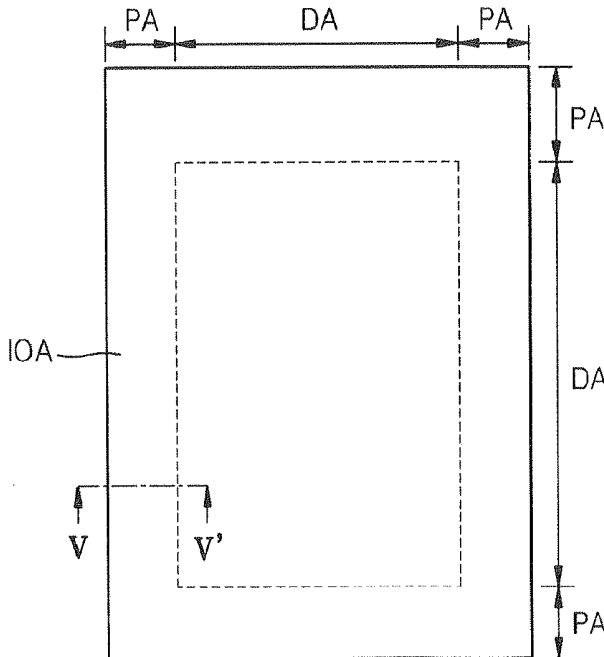
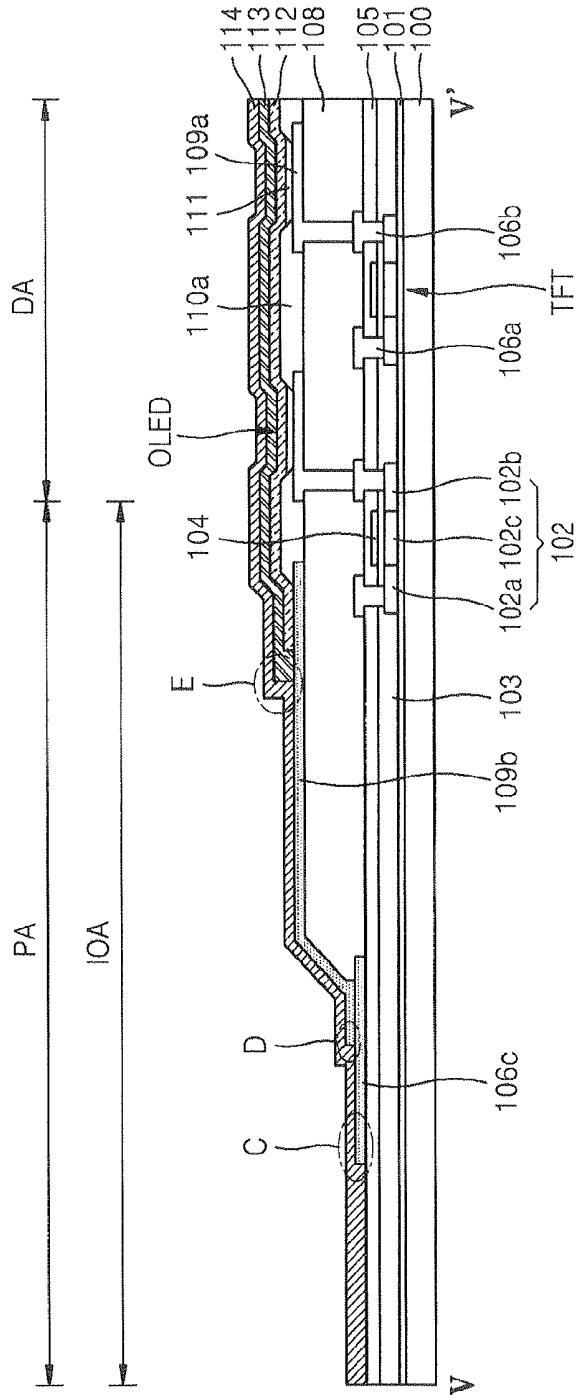



FIG. 6



## DISPLAY DEVICE AND ORGANIC LUMINESCENT DISPLAY DEVICE

[0001] This application is a continuation of U.S. patent application Ser. No. 15/871,115, filed Jan. 15, 2018, which is a continuation of U.S. patent application Ser. No. 13/840,879, filed Mar. 15, 2013, now U.S. Pat. No. 9,893,312, which claims priority to and the benefit of Korean Patent Application No. 10-2012-0137336, filed Nov. 29, 2012, the entire content of all of which is incorporated herein by reference.

### BACKGROUND OF THE INVENTION

#### Field of the Invention

[0002] An embodiment of the present invention relates to a display device and an organic luminescent display device, and more particularly, to a display device and an organic luminescent display device which include a thin film encapsulation structure.

#### Description of the Related Art

[0003] An organic luminescent display device using an organic light-emitting device is capable of displaying a moving image since the organic luminescent display device has a quicker response speed than a liquid crystal display (LCD) that is currently widely commercialized, and is receiving attention as a next-generation display device since the organic luminescent display device is self-emissive, has a wider viewing angle, and has higher luminance.

[0004] The organic light-emitting device includes a pixel electrode and a counter electrode, which face each other, and an emissive layer including an organic material disposed between the pixel electrode and the counter electrode. The organic light-emitting device is very sensitive to moisture, oxygen, and light, and thus may deteriorate by contacting them. Also, when oxygen or moisture is diffused into an organic layer, oxide is generated as an electrochemical charge transfer occurs on an interface between the pixel and counter electrodes and the organic layer, and a dark spot may occur as the oxide separates the organic layer and the pixel or counter electrode, thereby decreasing a life of the organic light-emitting device. Accordingly, the organic light-emitting device has a thin film encapsulation structure so as to block external moisture, oxygen, or light from being transferred into the organic light-emitting device.

[0005] The above information disclosed in this Background section is only for enhancement of understanding of the background of the described technology and therefore it may contain information that does not form the prior art that is already known in this country to a person of ordinary skill in the art.

### SUMMARY OF THE INVENTION

[0006] One or more embodiments of the present invention provide a display device and an organic light-emitting device, which include a thin film encapsulation structure.

[0007] In accordance with an aspect of the present invention, there is provided a display device including: a structure including a display area and a peripheral area surrounding the display area; and an inorganic encapsulation thin film disposed on the display and peripheral areas. The peripheral area includes at least one inorganic surface portion having a closed shape continuously surrounding the display area.

[0008] A surface portion of the display area may include at least one inorganic material.

[0009] The inorganic material may be deposited via an evaporation process.

[0010] The inorganic material may have an insulating property.

[0011] The inorganic material may be conductive and included in an electrode.

[0012] An entire surface of the structure may include at least one inorganic material.

[0013] The peripheral area may include at least one organic surface portion.

[0014] The organic surface portion may have a closed shape continuously surrounding the display area.

[0015] The organic surface portion may have an opened shape discontinuously surrounding the display area.

[0016] The inorganic surface portion may be disposed outermost portion of the peripheral area.

[0017] The inorganic surface portion may include a top surface of a first inorganic film, a top surface of a second inorganic film disposed on the first inorganic film, and a stepped surface formed by a side surface of the second inorganic film.

[0018] The first inorganic film may include a conductive inorganic material and the second inorganic film may include an insulating inorganic material.

[0019] The first inorganic film may include an insulating inorganic material and the second inorganic film may include a conductive inorganic material.

[0020] The first inorganic film may include a first conductive inorganic material and the second inorganic film may include a second conductive inorganic material different from the first conductive inorganic material.

[0021] The display device may further include a planarization film; a lower electrode disposed on the planarization film; an intermediate layer disposed on the lower electrode and comprising an organic material; and an upper electrode disposed on the intermediate layer, wherein the top surface of the first inorganic film may be spaced apart downward from a bottom surface of the planarization film.

[0022] The display device may further include a planarization film; a lower electrode disposed on the planarization film; an intermediate layer disposed on the lower electrode and including an organic material; and an upper electrode disposed on the intermediate layer, wherein at least a part of the inorganic surface portion may be spaced apart downward from a bottom surface of the planarization film.

[0023] In accordance with another aspect of the present invention, there is provided an organic luminescent display device including: a substrate; an inorganic insulating film disposed on the substrate; an inorganic wire portion disposed on at least the inorganic insulating film; an inorganic upper electrode connected to the inorganic wire portion and covering at least a display area of the substrate; and an inorganic encapsulation thin film covering the inorganic insulating film, the inorganic wire portion, and the inorganic upper electrode.

[0024] The organic luminescent display device may further include an inorganic insulating passivation film disposed between the inorganic upper electrode and the inorganic encapsulation thin film. The inorganic encapsulation thin film may contact top and side surfaces of the inorganic insulating passivation film.

**[0025]** The organic luminescent display device may further include: a planarization film formed on the inorganic insulating film and having a side surface; and an organic light-emitting device formed on the planarization film and including a lower electrode, an organic emissive layer, and the inorganic upper electrode, wherein the inorganic wire portion may include: an inorganic wire disposed on the inorganic insulating film; and an inorganic connecting portion disposed on the side and top surfaces of the planarization film to connect the inorganic wire and the inorganic upper electrode.

**[0026]** The side and top surfaces of the inorganic wire and the side and top surfaces of the inorganic connecting portion may contact the inorganic encapsulation thin film.

**[0027]** The organic luminescent display device may further include an inorganic capping film disposed between at least the inorganic insulating film and the inorganic encapsulation thin film. The inorganic capping film may include an opening exposing the inorganic wire.

**[0028]** The top surface of the inorganic capping film, the top surface of the inorganic wire exposed by the opening, and the top surface of the inorganic connecting portion may contact the inorganic encapsulation thin film.

**[0029]** The organic luminescent display device may further include an organic spacer disposed between the top surfaces of the inorganic wire and inorganic connecting portion and the inorganic encapsulation thin film.

**[0030]** In accordance with another aspect of the present invention, there is provided a display device including: a structure including a display area and a peripheral area surrounding the display area; and an inorganic encapsulation thin film disposed on the display and peripheral areas. The peripheral area includes at least one inorganic surface portion having a closed shape continuously surrounding the display area, and the inorganic surface portion includes at least two overlappingly selected from the group consisting of a first stepped surface, a second stepped surface, and a third stepped surface. The first stepped surface may be formed by a top surface of a first inorganic film including a conductive inorganic material, a top surface of a second inorganic film disposed on the first inorganic film and including an insulating inorganic material, and a side surface of the second inorganic film. The second stepped surface may be formed by a top surface of a first inorganic film including an insulating inorganic material, a top surface of a second inorganic film disposed on the first inorganic film and including a conductive inorganic material, and a side surface of the second inorganic film. The third stepped surface is formed by a top surface of a first inorganic film including a conductive inorganic material, a top surface of a second inorganic film disposed on the first inorganic film and comprising a different conductive inorganic material from the conductive inorganic material, and a side surface of the second inorganic film.

#### BRIEF DESCRIPTION OF THE DRAWINGS

**[0031]** A more complete appreciation of the invention, and many of the attendant advantages thereof, will be readily apparent as the same becomes better understood by reference to the following detailed description when considered in conjunction with the accompanying drawings in which like reference symbols indicate the same or similar components, wherein:

**[0032]** FIG. 1 is a plan view schematically illustrating a structure of a display device, according to an embodiment of the present invention;

**[0033]** FIG. 2 is a cross-sectional view taken along a line II-II' of FIG. 1;

**[0034]** FIG. 3 is a plan view schematically illustrating a structure of a display device, according to another embodiment of the present invention;

**[0035]** FIG. 4 is a plan view schematically illustrating a structure of a display device, according to another embodiment of the present invention;

**[0036]** FIG. 5 is a cross-sectional view taken along a line V-V' of FIG. 4; and

**[0037]** FIG. 6 is a cross-sectional view schematically illustrating a structure of a display device, according to an embodiment of the present invention.

#### DETAILED DESCRIPTION OF THE INVENTION

**[0038]** Hereinafter, the present invention will be described more fully with reference to the accompanying drawings, in which exemplary embodiments of the invention are shown.

**[0039]** So as to clearly describe the present invention, an element unrelated to the present invention is neither illustrated nor described, or simply illustrated or described. Also, in drawings, thicknesses and widths of layers and regions may be exaggerated for clarity.

**[0040]** In the drawings, like reference numerals denote like elements. The terms "first," "second," and the like used herein do not have limitative meanings, but are used to distinguish one element from another. It will also be understood that when a portion, such as a layer, a region, or an element is referred to as being "on" another portion, it can be directly on the other portion, or an intervening layers, region, or element may also be present.

**[0041]** As used herein, the term "and/or" includes any and all combinations of one or more of the associated listed items. Expressions such as "at least one of," when preceding a list of elements, modify the entire list of elements and do not modify the individual elements of the list. In the claims, the term of "'element' portion" refers to at least a portion of the entire 'element.' For example, the claimed term of "an inorganic surface portion" refers to at least a portion of the entire inorganic surface. In the claims, counting the number of 'element' portions is possible when the 'element' portions are separated from each other in a plan view such that merging the 'element' portions into one 'element' portion is not possible.

**[0042]** FIG. 1 is a plan view schematically illustrating a structure of a display device, according to an embodiment of the present invention. FIG. 2 is a cross-sectional view taken along a line II-II' of FIG. 1. FIG. 3 is a plan view schematically illustrating a structure of a display device, according to another embodiment of the present invention.

**[0043]** In reference to FIGS. 1 and 2, the display device includes a substrate **100**, a thin film transistor (TFT) array and an organic light-emitting device (OLED) that are formed on the substrate **100**, and an encapsulation thin film **114** sealing the OLED.

**[0044]** The substrate **100** supports the entire display device and maintains rigidity. The substrate **100** may have a flat top surface and be formed of a transparent insulating material. For example, the substrate **100** may be formed of glass. However, alternatively, the substrate **100** may be

formed of a plastic material, such as polyethersulphone (PES) or polyacrylate (PAR). Alternatively, the substrate **100** may be formed of an opaque material, such as a metal or a carbon fiber, or may be formed of flexible plastic, such as a polyimide (PI) film so as to realize a flexible display device.

**[0045]** The substrate **100** is divided into a display area DA and a peripheral area PA disposed around the display area DA. The display area DA is disposed at center of the substrate **100** and is an area where an image is displayed. The peripheral area PA is disposed at an edge of the substrate **100** to surround the display area DA and is an area where an image is not displayed.

**[0046]** A plurality of OLEDs emitting light for displaying an image are disposed in the display area DA according to pixels. A wire **106c** and a connecting pad **109b** for applying an electric signal or power to the OLED disposed on the display area DA are disposed in the peripheral area PA. Hereinafter, components disposed in the display area DA and the peripheral area PA are described in an order staked from the substrate **100**.

**[0047]** A buffer film **101** is formed on the substrate **100**. The buffer film **101** flattens the top surface of the substrate **100** and blocks impurities from penetrating into the substrate **100**. The buffer film **101** may have a multilayer or single layer structure formed of an inorganic material, such as silicon oxide (SiO<sub>x</sub>) and/or silicon nitride (SiN<sub>x</sub>), and may be formed via any one of various deposition methods. The buffer film **101** may not be formed as occasion demands.

**[0048]** A driving circuit unit is formed on the buffer film **101**. The driving circuit unit includes at least one TFT. The TFT is electrically connected to the OLED to drive the OLED. Although not illustrated, the driving circuit unit may further include at least one capacitor. Meanwhile, in FIG. 2, the TFT is a top gate type sequentially including an active layer **102**, a gate electrode **104**, a source electrode **106a**, and a drain electrode **106b**, but alternatively, any type of TFT may be employed, such as a bottom gate type.

**[0049]** The active layer **102** is formed on the buffer film **101**. The active layer **102** includes a semiconductor material, for example, may include amorphous silicon or polycrystalline silicon. However, alternatively, the active layer **102** may include an oxide semiconductor material, such as G-I-Z-O—[(In<sub>2</sub>O<sub>3</sub>)<sub>a</sub>(Ga<sub>2</sub>O<sub>3</sub>)<sub>b</sub>(ZnO)<sub>c</sub>], wherein a, b, and c are each a real number satisfying a ≥ 0, b ≥ 0 and c > 0. Aside from GIZO, the active layer **102** may include an oxide of a material selected from the group consisting of group 12, 13, and 14 metal elements, such as zinc (Zn), indium (In), gallium (Ga), tin (Sn), cadmium (Cd), germanium (Ge), and hafnium (Hf), and a combination thereof. The active layer **102** includes a source region **102a** and a drain region **102b** respectively contacting the source electrode **106a** and the drain electrode **106b**, and a channel region **102c** disposed between the source and drain regions **102a** and **102b**. When the active layer **102** includes amorphous silicon or polycrystalline silicon, impurities may be doped on the source and drain regions **102a** and **102b** if required.

**[0050]** A gate insulating film **103** is formed on the active layer **102**, and may have a multilayer or single layer structure formed of an inorganic material, such as silicon oxide and/or silicon nitride. The gate insulating film **103** insulates the active layer **102** and the gate electrode **104** from each other.

**[0051]** The gate electrode **104** is formed on the gate insulating film **103**. The gate electrode **104** is connected to a gate line (not shown) applying an on/off signal to the TFT. The gate electrode **104** may be formed of a low resistance metal material, and may have a multilayer or single layer structure formed of a conductive material, such as molybdenum (Mo), aluminum (Al), copper (Cu), or titanium (Ti).

**[0052]** An interlayer insulating film **105** is formed on the gate electrode **104**. The interlayer insulating film **105** insulates the source and drain electrodes **106a** and **106b** and the gate electrode **104** from each other. The interlayer insulating film **105** may have a multilayer or single layer structure formed of an inorganic material. For example, the inorganic material may be a metal oxide or a metal nitride, in detail, may be silicon oxide (SiO<sub>2</sub>), silicon nitride (SiN<sub>x</sub>), silicon oxynitride (SiON), aluminum oxide (Al<sub>2</sub>O<sub>3</sub>), titanium oxide (TiO<sub>2</sub>), tantalum oxide (Ta<sub>2</sub>O<sub>5</sub>), hafnium oxide (HfO<sub>2</sub>), or zinc oxide (ZrO<sub>2</sub>).

**[0053]** The source and drain electrodes **106a** and **106b** are formed on the interlayer insulating film **105**. The source and drain electrodes **106a** and **106b** respectively contact the source and drain regions **102a** and **102b** of the active layer **102** through contact holes formed through the interlayer insulating film **105** and the gate insulating film **103**. A capping film **107** and a planarization film **108** are formed on the TFT formed as above.

**[0054]** The capping film **107** may have a multilayer or single layer structure formed of an insulating inorganic material. For example, the insulating inorganic material may be metal oxide or metal nitride, in detail, SiO<sub>2</sub>, SiN<sub>x</sub>, SiON, Al<sub>2</sub>O<sub>3</sub>, TiO<sub>2</sub>, Ta<sub>2</sub>O<sub>5</sub>, HfO<sub>2</sub>, or ZrO<sub>2</sub>.

**[0055]** The planarization film **108** is formed to cover the capping film **107**. The planarization film **108** may have a multilayer or single layer structure formed of an inorganic material and/or an organic material. For example, the inorganic material may be metal oxide or metal nitride, in detail, SiO<sub>2</sub>, SiN<sub>x</sub>, SiON, Al<sub>2</sub>O<sub>3</sub>, TiO<sub>2</sub>, Ta<sub>2</sub>O<sub>5</sub>, HfO<sub>2</sub>, or ZrO<sub>2</sub>. Meanwhile, the organic material may be a common general polymer such as polymethylmethacrylate (PMMA) or polystyrene (PS), a polymer derivative having a phenol-based group, an acryl-based polymer, an imide-based polymer, an arylether-based polymer, an amide-based polymer, a fluorine-based polymer, a p-xylene-based polymer, a vinylalcohol-based polymer, or a blend thereof. Also, the planarization film **108** may have a complex stacked structure of an inorganic insulating film and an organic insulating film. The planarization film **108** resolves a stepped difference caused by the TFT array and flattens the top surface, thereby preventing a defect in the OLED caused by a lower unevenness.

**[0056]** The OLED is formed on top of the planarization film **108** corresponding to the display area DA. The OLED includes a lower electrode **109a** formed on the planarization film **108**, an upper electrode **112** facing the lower electrode **109a**, and an intermediate layer **111** disposed between the lower and upper electrodes **109a** and **112**. According to a light-emitting direction of the OLED, the display device is classified into a bottom emission type, a top emission type, and a dual emission type. In the bottom emission type, the lower electrode **109a** is used as a light transmissive electrode and the upper electrode **112** is used as a reflective electrode. In the top emission type, the lower electrode **109a** is used as a reflective electrode and the upper electrode **112** is used as a semi-transmissive electrode. In the dual emis-

sion type, both the lower and upper electrodes **109a** and **112** are used as light transmissive electrodes.

[0057] When the lower electrode **109a** is used as an anode, the lower electrode **109a** may include at least one material having a high work function selected from the group consisting of indium tin oxide (ITO), indium zinc oxide (IZO), zinc oxide (ZnO), indium oxide ( $\text{In}_2\text{O}_3$ ), indium gallium oxide (IGO), and aluminum zinc oxide (AZO). The lower electrode **109a** may be patterned in an island shape corresponding to each pixel. Also, the lower electrode **109a** may receive a current by being connected to the drain electrode **106b** of the TFT.

[0058] Meanwhile, a pixel define layer (PDL) **110a** formed of an insulating material is formed on the lower electrode **109a** to cover the lower electrode **109a**. The PDL **110a** may be formed of at least one organic insulating material selected from the group consisting of polyimide, polyamide, acryl resin, benzocyclobutene, and phenol resin, via a spin coating method. A predetermined opening defining a pixel is formed on the PDL **110a**. The intermediate layer **111** is formed in a region limited by at least the opening.

[0059] The intermediate layer **111** may include an organic emissive layer emitting red, green, or blue light, wherein the organic emissive layer may use a low molecular weight organic material or a high molecular weight organic material. When the organic emissive layer is a low molecular weight organic layer formed of a low molecular weight organic material, a hole transport layer (HTL) and a hole injection layer (HIL) are disposed towards the lower electrode **109a**, and an electron transport layer (ETL) and an electron injection layer (EIL) are stacked towards the upper electrode **112**, based on the organic emissive layer. Here, various layers as well as the HIL, the HTL, the ETL, and the EIL may be stacked if required.

[0060] In the above embodiment, the organic emissive layers are formed according to pixels. In this case, red, blue, or green light may be emitted according to pixels, and a pixel group emitting red, green, and blue lights may form one unit pixel. However, alternatively, the organic emissive layer may be commonly formed throughout pixels. For example, a plurality of organic emissive layers emitting red, green, and blue lights may be vertically stacked or mixed to emit a white light. Of course, a combination of colors for emitting a white light is not limited thereto. Here, a color converting layer or a color filter may be separately used to convert the white light to a predetermined color.

[0061] The upper electrode **112** may be formed of a conductive inorganic material. When the upper electrode **112** is used as a cathode, the upper electrode **112** may be formed of Al, Mg, or Ag having a low work function. The upper electrode **112** may be a common electrode formed throughout the display area DA where an image is realized. Here, the upper electrode **112** may be formed via an evaporation process that does not damage the intermediate layer **111**.

[0062] Meanwhile, the polarities of the lower electrode **109a** and the upper electrode **112** may be interchanged.

[0063] An insulating passivation film **113** is formed on the upper electrode **112**. A work function of the upper electrode **112** may be changed while the encapsulation thin film **114** is formed via a sputtering process or a plasma enhanced chemical vapor deposition (PECVD) process. Also, the organic material included in the intermediate layer **111** may

be damaged. Thus, the insulating passivation film **113** may be formed to cover the upper electrode **112**. The insulating passivation film **113** may have a multilayer or single layer structure formed of an insulating inorganic material. For example, the insulating inorganic material may be metal oxide, metal nitride, or metal fluoride. In detail, the insulating inorganic material may be fluoride of alkali metal. When the OLED is a top emission type or dual emission type, light may penetrate through the insulating passivation film **113**. The insulating passivation film **113** is formed through an evaporation process that does not damage the upper electrode **112** and the intermediate layer **111**. According to an embodiment, in the top emission type, a conductive or semiconductor organic layer may be further formed between the upper electrode **112** and the insulating passivation film **113**. The conductive or semiconductor organic layer may include light extraction efficiency. The conductive or semiconductor organic layer may be formed through an evaporation process.

[0064] Meanwhile, the upper electrode **112** may receive an electric signal or power by being connected to a wire portion of the peripheral area PA.

[0065] The wire portion includes the wire **106c** and the connecting pad **109b**.

[0066] The wire **106c** applies an electric signal or power received from the outside to the upper electrode **112**. Thus, the wire **106c** is formed of a conductive inorganic material capable of satisfactorily transferring a current, for example, may have a multilayer or single layer structure formed of at least one metal selected from the group consisting of aluminum (Al), platinum (Pt), palladium (Pd), silver (Ag), magnesium (Mg), gold (Au), nickel (Ni), neodymium (Nd), iridium (Ir), chromium (Cr), nickel (Li), calcium (Ca), molybdenum (Mo), titanium (Ti), tungsten (W), and copper (Cu). The wire **106c** is formed on the interlayer insulating film **105**. The wire **106c** may be simultaneously formed while forming the source and drain electrodes **106a** and **106b** of the TFT. Here, the wire **106c** may be formed of the same conductive inorganic material as the source and drain electrodes **106a** and **106b**.

[0067] Meanwhile, since the wire **106c** is formed on the interlayer insulating film **105**, a top surface (indicated by X) of the wire **106c** is located downward from a bottom surface (indicated by Y) of the planarization film **108**. Thus, when a stress is applied in a parallel direction to the planarization film **108**, a structure between the top surface of the wire **106c** and the bottom surface of the planarization film **108** may function as a buffer. Accordingly, even when a stress is applied, adhesion between the wire **106c** and the encapsulation thin film **114** may be maintained.

[0068] The capping film **107** is formed to cover the wire **106c**. As described above, the capping film **107** may have a multilayer or single layer structure formed of an insulating inorganic material. An opening is formed on the capping film **107** to expose a part of the wire **106c**. In other words, the capping film **107** is formed throughout the display area DA and the peripheral area PA, and includes an opening that covers the edge of the wire **106c** and exposes the center of the wire **106c**. The wire **106c** and the upper electrode **112** are electrically connected to each other, but are physically apart from each other since they are formed in different layers. Accordingly, the connecting pad **109b** electrically connecting the wire **106c** and the upper electrode **112** is required.

The opening is formed on the capping film 107 as a contact hole for the connecting pad 109b to contact the wire 106c.

[0069] The connecting pad 109b transfers an electric signal or power received from the wire 106c to the upper electrode 112. The connecting pad 109b functions as a bridge or link. Accordingly, the connecting pad 109b is formed of a conductive inorganic material capable of satisfactorily transferring a current, and may have a multilayer or single layer structure formed of one or more metals selected from the group consisting of Al, Pt, Pd, Ag, Mg, Au, Ni, Nd, Ir, Cr, Li, Ca, Mo, Ti, W, and Cu. Meanwhile, a side portion of the planarization film 108 described above is disposed in the peripheral area PA, wherein the connecting pad 109b is disposed along side and top surfaces of the planarization film 108. One end of the connecting pad 109b contacts the wire 106c exposed by the opening of the capping film 107, and the other end contacts the upper electrode 112. According to an embodiment, the connecting pad 109b may be formed together with the lower electrode 109a in the same material as the lower electrode 109a.

[0070] An organic spacer 110b is formed on a region where the wire 106c and the connecting pad 109b contact each other. The organic spacer 110b may be formed of at least one organic insulating material selected from the group consisting of polyimide, polyamide, acryl resin, benzocyclobutene, and phenol resin, and may be formed together with the PDL 110a in the same material as the PDL 110a. The organic spacer 110b may have a closed shape continuously surrounding the display area DA, or an opened shape discontinuously surrounding the display area DA. The organic spacer 110b supports a mask during an evaporation process for forming various films in the display area DA. Also, the organic spacer 110b operates as a buffer with respect to a temporary shock applied to the peripheral area PA, and absorbs the temporary shock. Meanwhile, the organic spacer 110b is formed on the region where the wire 106c and the connecting pad 109b contact each other, and thus prevents the connecting pad 109b from detached and prevents a connection defect.

[0071] The encapsulation thin film 114 is formed throughout the substrate 100 to cover all of the display area DA and the peripheral area PA. The encapsulation thin film 114 is formed to protect the OLED from external moisture or oxygen. The encapsulation thin film 114 may have a multilayer or single layer structure formed of an insulating inorganic material. For example, the insulating inorganic material may be metal oxide or metal nitride, in detail, SiO<sub>2</sub>, SiN<sub>x</sub>, SiON, Al<sub>2</sub>O<sub>3</sub>, TiO<sub>2</sub>, Ta<sub>2</sub>O<sub>5</sub>, HfO<sub>2</sub>, or ZrO<sub>2</sub>.

[0072] In the display area DA, the encapsulation thin film 114 covers the insulating passivation film 113 formed on the upper electrode 112. Since the insulating passivation film 113 is formed of an insulating inorganic material and the encapsulation thin film 114 is also formed of an insulating inorganic material, they have good adhesion. Accordingly, the display device may have a strong sealing structure in the display area DA.

[0073] Meanwhile, the peripheral area PA includes at least one inorganic area IOA having a closed shape continuously surrounding the display area DA. In detail, the peripheral area PA includes a first inorganic area IOA1 and a second inorganic area IOA2, and an organic area OA disposed therebetween. Here, the inorganic area IOA means an area where the encapsulation thin film 114 formed of the insulating inorganic material inorganic-inorganic contacts an

inorganic surface portion formed on the substrate 100. Also, the organic area OA means an area where the encapsulation thin film 114 formed of the insulating inorganic material inorganic-organic contacts an organic surface portion formed on the substrate 100.

[0074] The first inorganic area IOA1 is located in an outermost edge of the substrate 100. The first inorganic area IOA1 is an area where the capping film 107 formed of the insulating inorganic material and the encapsulation thin film 114 formed of the insulating inorganic material contact each other. Also, as in a region A of FIG. 2, the first inorganic area IOA1 also includes an area where a stepped surface formed by the top surface of the wire 106c including the conductive inorganic material exposed by the opening of the capping film 107 and the side surface of the capping film 107 formed by the opening contacts the encapsulation thin film 114. As such, by including the first inorganic area IOA1 contacting an inorganic surface on the encapsulation thin film 114 and the substrate 100, a strong encapsulation structure may be realized and moisture permeability may be effectively prevented. Specifically, since the first inorganic area IOA1 is located at the outermost edge of the substrate 100, moisture or oxygen from a side portion of the display device may be effectively blocked. Also, since the first inorganic area IOA1 includes the stepped surface as shown in the region A, the stepped surface may operate as a buffer while a structure expands due to heat, thereby maintaining adhesion between the encapsulation thin film 114 and the lower surface.

[0075] In detail, the wire 106c and the capping film 107 each expands due to heat generated in the wire 106c according to a current flow or heat transferred from outside/inside of the display device. Here, since the wire 106c and the capping film 107 are formed of different materials, the rates of expansion are different. Due to the different rates of expansion, adhesion between the encapsulation thin film 114 and the wire 106c, and the capping film 107 may deteriorate. However, according to the current embodiment, since a contact region between the encapsulation thin film 114 and the lower structure is increased by the stepped surface like the region A, strong adhesion may be maintained despite of heat. Also, since the stepped surface like the region A may function as a type of buffer providing a spatial margin regarding expansion, adhesion between the encapsulation thin film 114 and the lower structure may be prevented from being decreased due to expansion.

[0076] Then, the second inorganic area IOA2 is disposed adjacent to the display area DA. The second inorganic area IOA2 includes an area where the connecting pad 109b formed of the conductive inorganic material contacts the insulating passivation film 113 formed of the insulating inorganic material and the encapsulation thin film 114 formed of the insulating inorganic material. Also, the second inorganic area IOA2 includes an area where a stepped surface formed by the side surface of the insulating passivation film 113 on the connecting pad 109b contacts the encapsulation thin film 114 as shown in a region B of FIG. 2. As such, in the current embodiment, by additionally including the second inorganic area IOA2 as well as the first inorganic area IOA1 contacting an inorganic surface on the encapsulation thin film 114 and the substrate 100, an encapsulation structure may be further strong, and moisture permeability may be effectively blocked. Also, since the second inorganic area IOA2 also includes the stepped surface like the region B, the stepped surface may function as a buffer

while the structure expands due to heat, thereby maintaining adhesion between the encapsulation thin film 114 and the lower surface.

[0077] In detail, the connecting pad 109b and the insulating passivation film 113 each expands due to heat generated in the connecting pad 109b according to a current flow or heat transferred from outside/inside of the OLED. Here, since the connecting pad 109b and the insulating passivation film 113 are formed of different materials, the rates of expansion are different. Due to the different rates of expansion, adhesion between the encapsulation thin film 114 and the connecting pad 109b, and the insulating passivation film 113 may deteriorate. However, according to the current embodiment, since a contact region between the encapsulation thin film 114 and the lower structure is increased by the stepped surface like the region B, strong adhesion may be maintained despite of heat. Also, since the stepped surface may function as a type of buffer providing a spatial margin regarding expansion, adhesion between the encapsulation thin film 114 and the lower structure may be prevented from being decreased due to expansion.

[0078] In the peripheral area PA, the organic area OA is formed between the first inorganic area IOA1 and the second inorganic area IOA2. The organic area OA is an area where the organic spacer 110b and the encapsulation thin film 114 formed of the insulating inorganic material contact each other.

[0079] As shown in FIG. 1, if the organic spacer 110b has a closed shape continuously surrounding the display area DA, the organic area OA also has a closed shape continuously surrounding the display area DA. Alternatively, as shown in FIG. 3, if the organic spacer 110b has an opened shape discontinuously surrounding the display area DA, the organic area OA also has an opened shape discontinuously surrounding the display area DA.

[0080] FIG. 4 is a plan view schematically illustrating a structure of a display device, according to another embodiment of the present invention. FIG. 5 is a cross-sectional view taken along a line V-V of FIG. 4.

[0081] The current embodiment of FIGS. 4 and 5 is different from the embodiment of FIGS. 1 through 3 in that the organic spacer 110b, the capping film 107, and the insulating passivation film 113 are not used. Since components of FIGS. 4 and 5 denoted by the same reference numerals as those of FIGS. 1 through 3 have the same or similar functions as the components of FIGS. 1 through 3, overlapping descriptions thereof will not be repeated. According to the current embodiment, at least one of the organic spacer 110b, the capping film 107, and the insulating passivation film 113 may be employed.

[0082] In reference to FIGS. 4 and 5, in the display area DA, the encapsulation thin film 114 directly covers the upper electrode 112. Here, since the upper electrode 112 is formed of a conductive inorganic material and the encapsulation thin film 114 is formed of an insulating inorganic material, the upper electrode 112 and the encapsulation thin film 114 have satisfactory adhesion via inorganic-inorganic contact. Accordingly, like the previous embodiment the display device may have a strong sealing structure in the display area DA.

[0083] Meanwhile in FIGS. 4 and 5, only the inorganic area IOA is included in the peripheral area PA. The inorganic area IOA is located at the outermost edge of the substrate 100 surrounding the display area DA. The inorganic area

IOA includes an area where the interlayer insulating film 105 formed of an insulating inorganic material, the wire 106c formed of a conductive inorganic material, and the connecting pad 109b contact the encapsulation thin film 114 formed of an insulating inorganic material. Specifically, the inorganic area IOA includes a stepped surface formed by a side surface of the wire 106c contacting the encapsulation thin film 114 like a region C and a stepped surface formed by a side surface of the connecting pad 109b contacting the encapsulation thin film 114 like a region D of FIG. 5.

[0084] In particular, since the capping film 107 is not used in the embodiment of FIGS. 4 and 5, the side surface of the wire 106c is exposed on the interlayer insulating film 105. Accordingly, a stepped surface like a region C is further formed by the side surface of the wire 106c.

[0085] As described above, the stepped surfaces included in the inorganic area IOA operates as a buffer while the structure expands due to heat, thereby maintaining adhesion between the encapsulation thin film 114 and the lower surface. In detail, the wire 106c, the connecting pad 109b, and the interlayer insulating film 105 each expands due to heat generated in the wire 106c and the connecting pad 109b according to a current flow or heat transferred from outside/inside of the display device. When the wire 106c, the connecting pad 109b, and the interlayer insulating film 105 are formed of different materials, the rates of expansion may be different, thereby deteriorating adhesion toward the encapsulation thin film 114. However, since the stepped surfaces like the regions C and D may increase a contact area and operate as a buffer with respect to expansion, adhesion of top surfaces and/or side surfaces of the wire 106c, the connecting pad 109b, and the interlayer insulating film 105 to a bottom surface of the encapsulation thin film 114 may be strongly and continuously maintained.

[0086] FIG. 6 is a cross-sectional view schematically illustrating a structure of a display device, according to an embodiment of the present invention. FIG. 6 corresponds to the cross-sectional view taken along the line V-V of FIG. 4, like FIG. 5.

[0087] Referring to FIG. 6, unlike FIG. 5, the passivation film 113 formed of an insulating inorganic material is further formed on the upper electrode 112. Since components of FIG. 6 denoted by the same reference numerals as those of FIGS. 1 through 5 have the same or similar functions as the components of FIGS. 1 through 5, overlapping descriptions thereof will not be repeated.

[0088] Like the region B of FIG. 2, a region E of FIG. 6 the stepped surface formed by the side surface of the passivation film 113 on the connecting pad 109b contacts the encapsulation thin film 114. The stepped surface like the region E may strongly maintain the adhesion of the bottom surface of the encapsulation thin film 114 and the connecting pad 109b to the passivation film 113, like the region B.

[0089] Herein, the display device is an organic luminescent display device including the OLED, but alternatively, the display device may have another structure including the inorganic encapsulation thin film 114.

[0090] According to another embodiment of the present invention, an inorganic area may include at least two stepped surfaces overlappingly selected from among a first stepped surface like the region A of FIG. 2, a second stepped surface like the region B of FIG. 2 or the region E of FIG. 6, and a third stepped surface like the region C or D of FIGS. 5 and 6. In this case, strong adhesion may be maintained despite of

different rates of expansion between an insulator and a conductor and a stress applied in a parallel direction to a substrate. Although not illustrated, a thin film formed of an organic material and a thin film formed of an inorganic material may be further alternately stacked on the inorganic encapsulation thin film 114 to form an encapsulation structure. Here, an organic layer may be formed of polymer, and in detail, may be a single film or a stacked film formed of any one of polyethyleneterephthalate, polyimide, polycarbonate, epoxy, polyethylene, and polyacrylate. An uppermost layer externally exposed in such an encapsulation structure may be an inorganic layer so as to prevent moisture permeability to an OLED. Such an encapsulation structure may include at least one sandwich structure in which at least one organic layer is inserted between at least two inorganic layers. Alternatively, the encapsulation structure may include at least one sandwich structure in which at least one inorganic layer is inserted between at least two organic layers.

[0091] For example, such an encapsulation structure may include a first inorganic layer corresponding to the inorganic encapsulation thin film 114, a first organic layer, and a second inorganic layer sequentially from a top of the OLED. Alternatively, the encapsulation structure may include a first inorganic layer, a first organic layer, a second inorganic layer, a second organic layer, and a third inorganic layer sequentially from the top of the OLED. Alternatively, the encapsulation structure may include a first inorganic layer, a first organic layer, a second inorganic layer, a second organic layer, a third inorganic layer, a third organic layer, and a fourth inorganic layer sequentially from the top of the OLED. Here, the first organic layer may have a smaller area than the second inorganic layer, and the second organic layer may have a smaller area than the third inorganic layer. Also, the first organic layer may be completely covered by the second inorganic layer, and the second organic layer may also be completely covered by the third inorganic layer.

[0092] Meanwhile, the OLED may be efficiently sealed as a sealing substrate adhered by a sealing member, such as a sealant or frit, is further formed on an inorganic encapsulation thin film or an encapsulation structure.

[0093] Meanwhile, active type driving is described herein but alternatively, a passive type driving that does not use a TFT may also be used. Here, a layer where a TFT array is formed is omitted.

[0094] According to one or more embodiments of the present invention, a stronger sealing structure may be realized by adhering an inorganic surface portion of a display device to an inorganic encapsulation thin film.

[0095] While the present invention has been particularly shown and described with reference to exemplary embodiments thereof, it will be understood by those of ordinary skill in the art that various changes in form and details may be made therein without departing from the spirit and scope of the present invention as defined by the following claims.

What is claimed is:

1. A method of manufacturing an electroluminescent device, the method comprising:

forming a lower structure having a peripheral area and an emission area, the emission area being surrounded by the peripheral area and comprising an electroluminescent unit comprising a lower electrode, an electroluminescent layer on the lower electrode, and an upper electrode on the electroluminescent layer;

forming a passivation film on the upper electrode by an evaporation process such that an outline of the passivation film is located outside an outline of the upper electrode, the passivation film comprising an inorganic material having a substantially insulating property; and forming a flexible encapsulation multilayer on the emission area and peripheral area of the lower structure, the flexible encapsulation multilayer comprising at least three layers and having a bottom surface comprising only at least one inorganic material deposited by at least one non-evaporation process; and

wherein a surface of the peripheral area comprises an inorganic surface portion located outside the upper electrode in a plan view and substantially surrounding the emission area of the lower structure, and

wherein an entirety of the inorganic surface portion directly contacts the bottom surface of the flexible encapsulation multilayer.

2. The method of claim 1, wherein the inorganic material included in the passivation film comprises a fluoride of an alkali metal.

3. The method of claim 1, wherein the passivation film directly contacts the upper electrode and the bottom surface of the flexible encapsulation multilayer.

4. The method of claim 1, further comprising:

forming an organic layer between the upper electrode and the passivation film by an evaporation process, the organic layer being conductive or semi-conductive and directly contacting the upper electrode.

5. The method of claim 4, wherein the passivation film directly contacts the organic layer.

6. The method of claim 4, wherein the passivation film directly contacts top and side surfaces of a structure comprising the upper electrode and the organic layer.

7. The method of claim 1, wherein the lower electrode is an individual layer and the upper electrode is a common layer.

8. The method of claim 7, wherein the outline of the upper electrode is located outside an outline of the lower electrode and an outline of the flexible encapsulation multilayer is located outside the outline of the passivation film.

9. The method of claim 8, wherein the inorganic surface portion is located between the outline of the flexible encapsulation multilayer and the outline of the passivation film.

10. The method of claim 1, wherein the lower structure comprises a lower inorganic insulating film expanding below a surface of the lower structure to correspond to the emission area and the peripheral area, and a portion of the lower structure positioned between the inorganic surface portion and the lower inorganic insulating film comprises only one or more inorganic materials.

11. A method of manufacturing an electroluminescent device, the method comprising:

forming a lower structure having a peripheral area and an emission area, the emission area being surrounded by the peripheral area and comprising an electroluminescent unit comprising a lower electrode, an electroluminescent layer on the lower electrode, and an upper electrode on the electroluminescent layer;

forming an organic layer on the upper electrode by an evaporation process, the organic layer being conductive or semi-conductive and directly contacting top and side

surfaces of the upper electrode such that an outline of the organic layer is located outside an outline of the upper electrode; and

forming a flexible encapsulation multilayer on the emission and peripheral areas of the lower structure, the flexible encapsulation multilayer comprising at least three layers and having a bottom surface comprising only at least one inorganic material deposited by at least one non-evaporation process; and

wherein a surface of the peripheral area comprises an inorganic surface portion located outside the upper electrode in a plan view and substantially surrounding the emission area of the lower structure, and

wherein an entirety of the inorganic surface portion directly contacts the bottom surface of the flexible encapsulation multilayer.

**12.** The method of claim **11**, further comprising:

forming a passivation film between the organic layer and the bottom surface of the flexible encapsulation multilayer via an evaporation process by using an inorganic material having a substantially insulating property.

**13.** The method of claim **12**, wherein the inorganic material included in the passivation film comprises fluoride of an alkali metal.

**14.** The method of claim **12**, wherein the passivation film directly contacts the organic layer and the bottom surface of the flexible encapsulation multilayer.

**15.** The method of claim **11**, wherein the bottom surface of the flexible encapsulation multilayer directly contacts side and top surfaces of a structure comprising the upper electrode and the organic layer.

**16.** The method of claim **11**, wherein the lower electrode is an individual layer and the upper electrode is a common layer.

**17.** The method of claim **16**, wherein the outline of the upper electrode is located outside an outline of the lower electrode and an outline of the flexible encapsulation multilayer is located outside the outline of the organic layer.

**18.** The method of claim **17**, wherein the inorganic surface portion is located between the outline of the flexible encapsulation multilayer and the outline of the organic layer.

**19.** The method of claim **11**, wherein the lower structure comprises a lower inorganic insulating film expanding below a surface of the lower structure to correspond to the emission area and the peripheral area, and a portion of the lower structure positioned between the inorganic surface portion and the lower inorganic insulating film comprises only one or more inorganic materials.

**20.** A method of manufacturing an electroluminescent device, the method comprising:

forming a lower structure having a peripheral area and an emission area, the emission area being surrounded by the peripheral area and comprising an electroluminescent unit comprising a lower electrode, an electroluminescent layer on the lower electrode, and an upper electrode on the electroluminescent layer; and

forming a flexible encapsulation multilayer having a bottom surface on the emission and peripheral areas of the lower structure such that the bottom surface of the flexible encapsulation multilayer directly contacts a side surface of the upper electrode, the flexible encapsulation multilayer comprising at least three layers, the bottom surface of the flexible encapsulation multilayer comprising only at least one inorganic material deposited by at least one non-evaporation process; and

wherein a surface of the peripheral area comprises an inorganic surface portion located outside the upper electrode in a plan view and substantially surrounding the emission area of the lower structure; and

wherein an entirety of the inorganic surface portion directly contacts the bottom surface of the flexible encapsulation multilayer; and

further comprising forming an organic layer directly on the upper electrode by an evaporation process, the organic layer being conductive or semi-conductive.

**21.** The method of claim **20**, wherein an outline of the organic layer is located between an outline of the emission area and an outline of the flexible encapsulation multilayer.

\* \* \* \* \*

专利名称(译)	显示装置和有机发光显示装置		
公开(公告)号	<a href="#">US20190207159A1</a>	公开(公告)日	2019-07-04
申请号	US16/298961	申请日	2019-03-11
[标]申请(专利权)人(译)	三星显示有限公司		
申请(专利权)人(译)	三星DISPLAY CO. , LTD.		
当前申请(专利权)人(译)	三星DISPLAY CO. , LTD.		
[标]发明人	PARK MYOUNG SEO		
发明人	PARK, MYOUNG-SEO		
IPC分类号	H01L51/52 H01L27/32		
CPC分类号	H01L51/5253 H01L27/3244 H01L27/3276 C09K15/02 H05B33/04		
优先权	1020120137336 2012-11-29 KR		
其他公开文献	US10600995		
外部链接	<a href="#">Espacenet</a> <a href="#">USPTO</a>		

摘要(译)

提供一种显示装置，包括：包括显示区域和围绕显示区域的外围区域的结构；无机封装薄膜设置在显示器和外围区域上。周边区域包括连续的具有封闭形状的至少一个无机表面部分。

